

PLAN 1:50

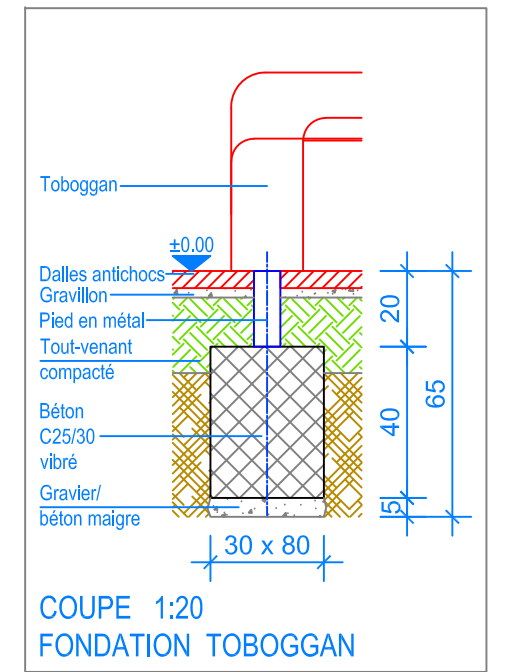
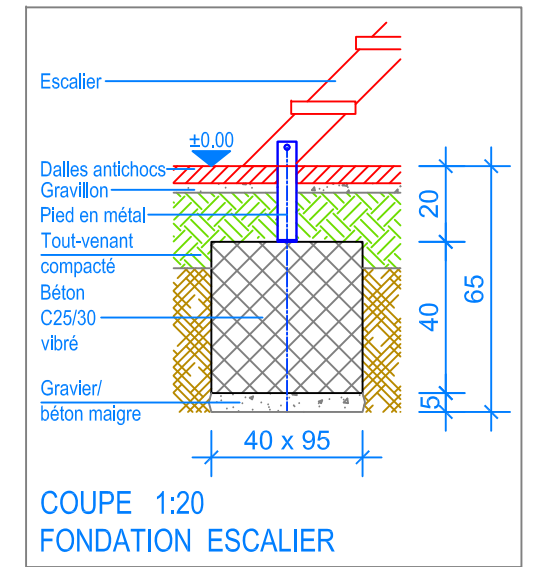
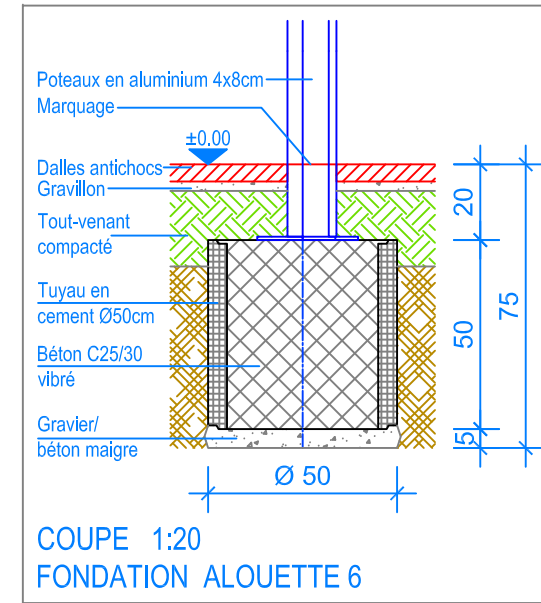

- Limite minimale avec dalles antichocs
- - - Espace de chute