

GRUNDRISS 1:50

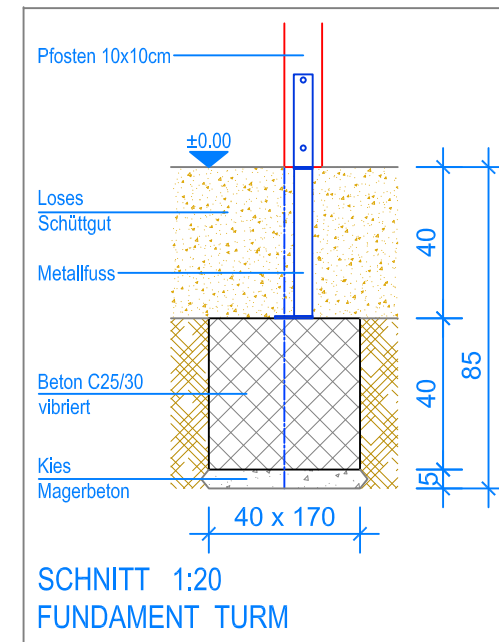

SCHNITT 1:20
FUNDAMENT TURM

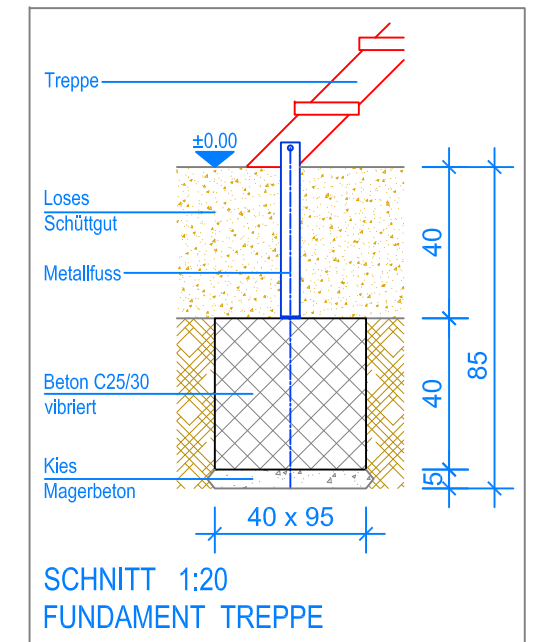

SCHNITT 1:20
FUNDAMENT TREPPE

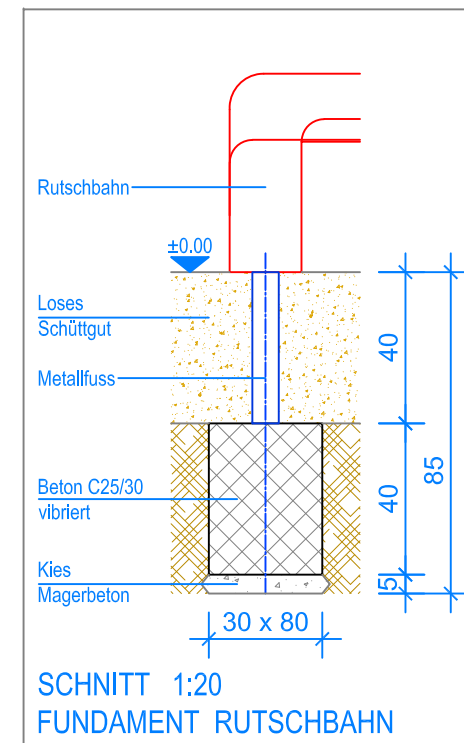

SCHNITT 1:20
FUNDAMENT RUTSCHBAHN

Beispiel:
Variante 3.65.30 / PH = + 180 cm

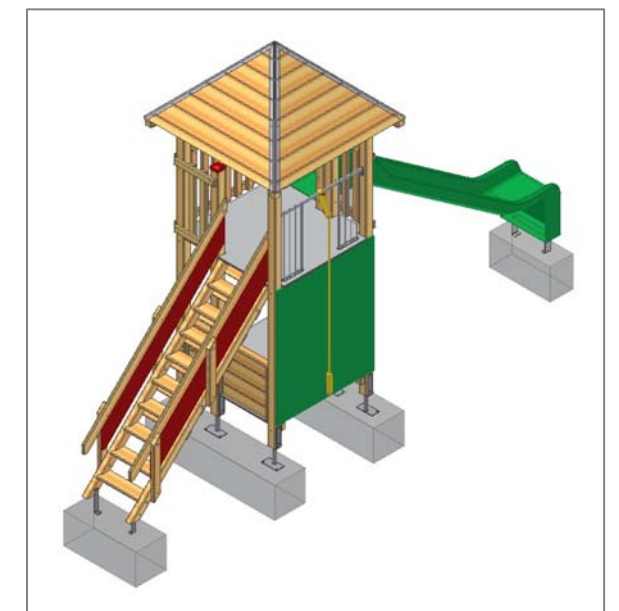

- Aussenkante loses Schüttgut
- - - Fallraum