

PLAN 1:50

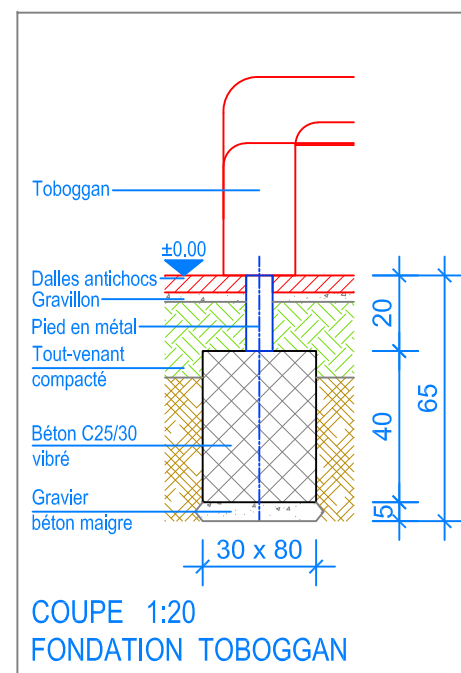

Exemple:
Variante 3.65.30 / HP = + 180 cm

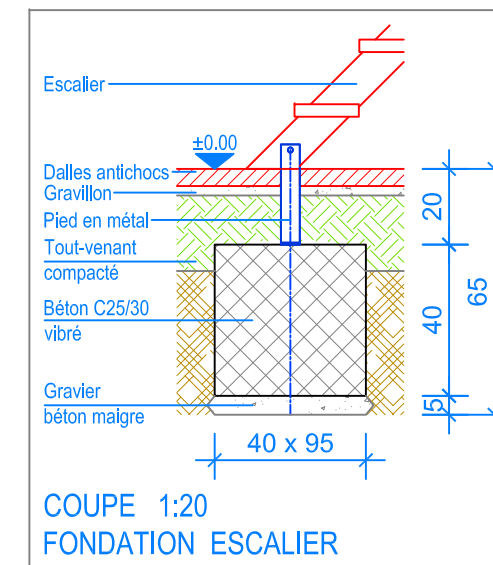
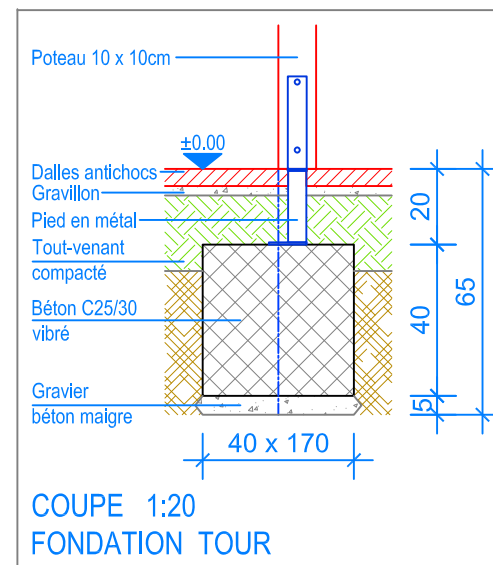

- Limite minimale avec dalles antichocs
- - - Espace de chute