

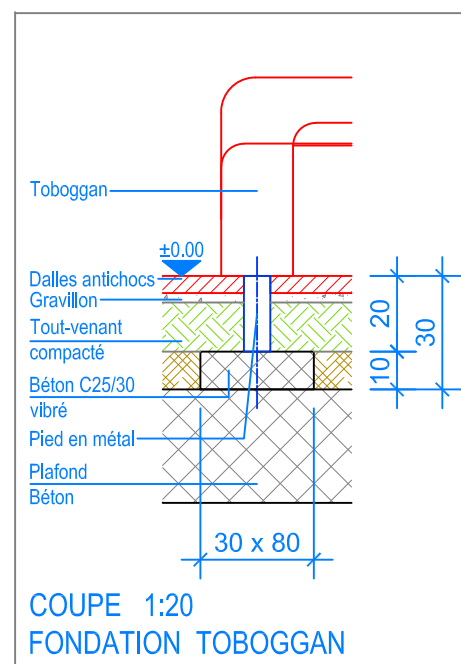

PLAN 1:50

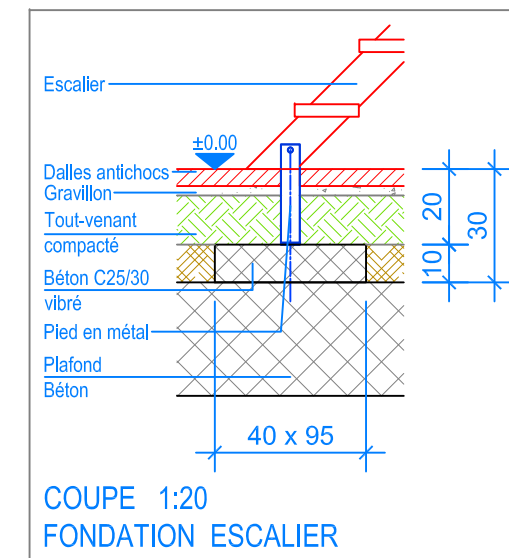

Exemple:
Variante 3.65.30 / HP = + 180 cm

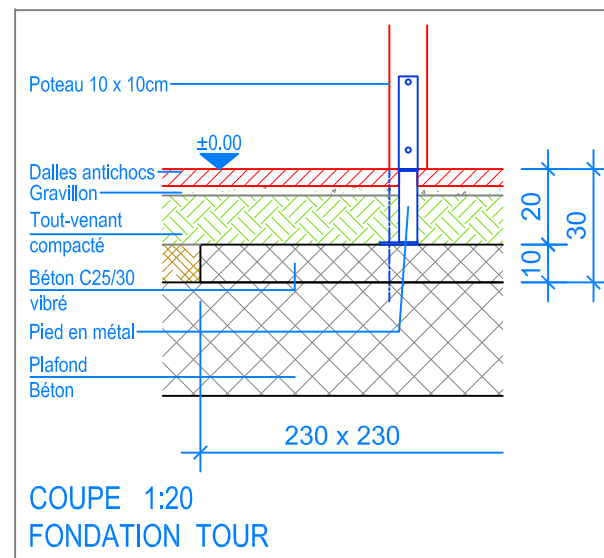

- Limite minimale avec dalles antichocs
- - - Espace de chute

 <p>Fuchs Thun AG Tempelstrasse 11, CH-3608 Thun Tel. 033 334 30 00 Internet: www.fuchsthun.ch E-Mail: info@fuchsthun.ch Conseil et vente Suisse romande Tél. 079 314 64 50</p>	Objekt: Plan des fondations dalles antichocs, toiture plate: 3.65.29 Tour Quadro avec paroi à grimper, HP = +140 cm		
	Dat.: 30.04.2012	Rev.: 23.01.2019 - SM	PLNr.: 3.65.29
	Gez.: C. Oeschger	Rev.: 11.04.2024 - MT	Mst.: 1:50 / 1:20